



[www.pro-cnc.com.pl](http://www.pro-cnc.com.pl)

PRODUCTION  
SPECIALIZED  
MACHINES

ul. Głudna 37, 05-620 Błędów

+(48) 538 358 588

biuro@pro-cnc.com.pl



# **EASY-PICKER**

## **APPLE HARVESTER**

The harvester for harvesting industrial apples is adapted for a 3-point hitching system. The device is designed for harvesting apples on the ground. Movable belts lift the fruit and separate the leaves.

The device is controlled from the tractor's hydraulics or joystick.

The machine can be powered directly from the tractor or from the aggregate mounted on the machine, driven by the PTO.

The picking takes place in trolleys fastened behind the machine, and the apples are transported to the boxes through gutters or by means of a trolley with a lift on which BIG BAG bags are hung.

### **MAIN ADVANTAGES OF WORKING WITH PRO-ONE**

- **reduction of costs and working time**
- **speed of the procedure in the orchard**
- **easier harvesting from the fruit-bearing wall**
- **improvement of fruit quality**

## EASY-PICKER





# EASY-PICKER



## EASY-PICKER





## EASY-PICKER WITH ONE-SIDED HARROW



## ONE-SIDED HARROW

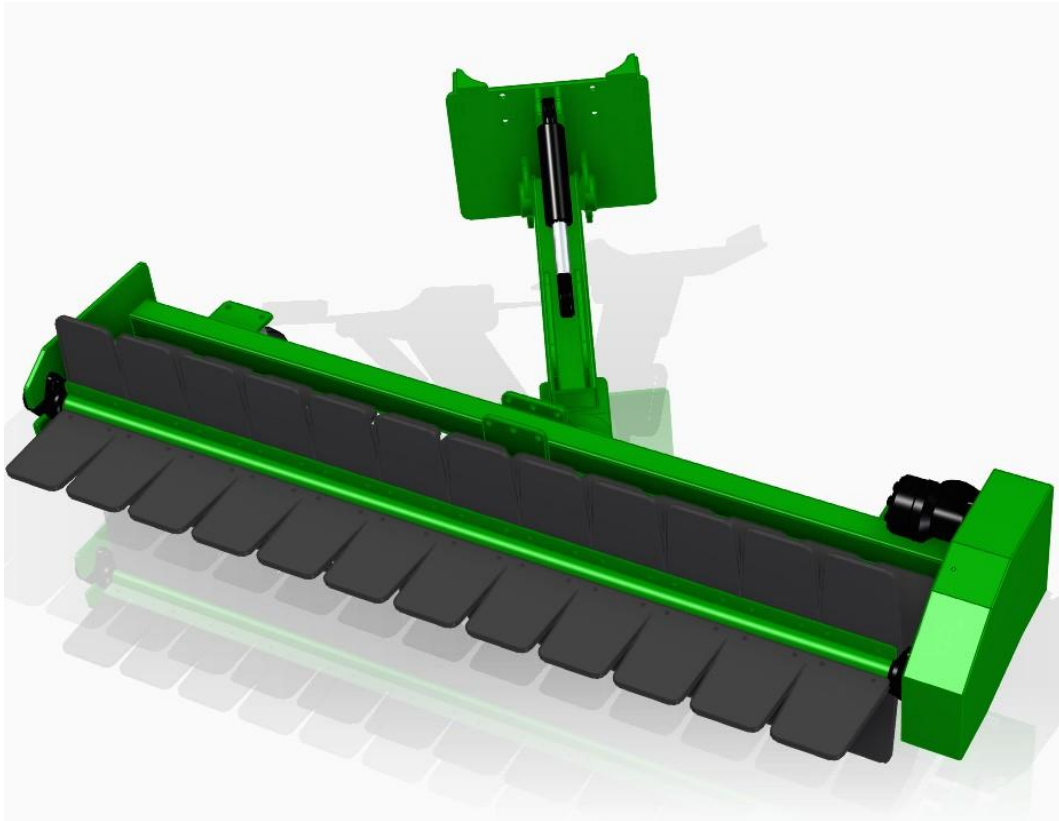

## EASY-PICKER WITH DOUBLE-SIDED HARROW





## EASY-PICKER WITH DOUBLE-SIDED HARROW



## DOUBLE-SIDED HARROW

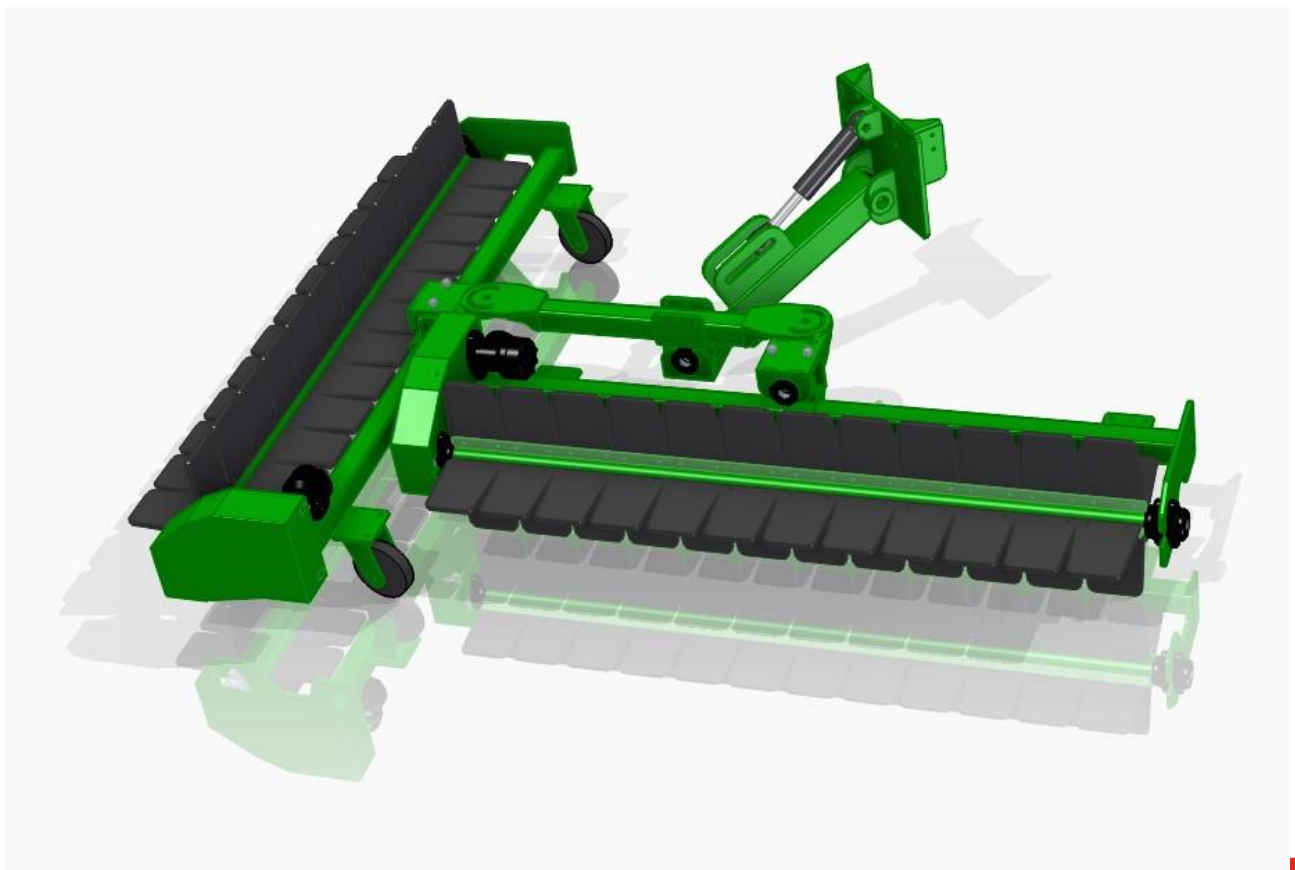
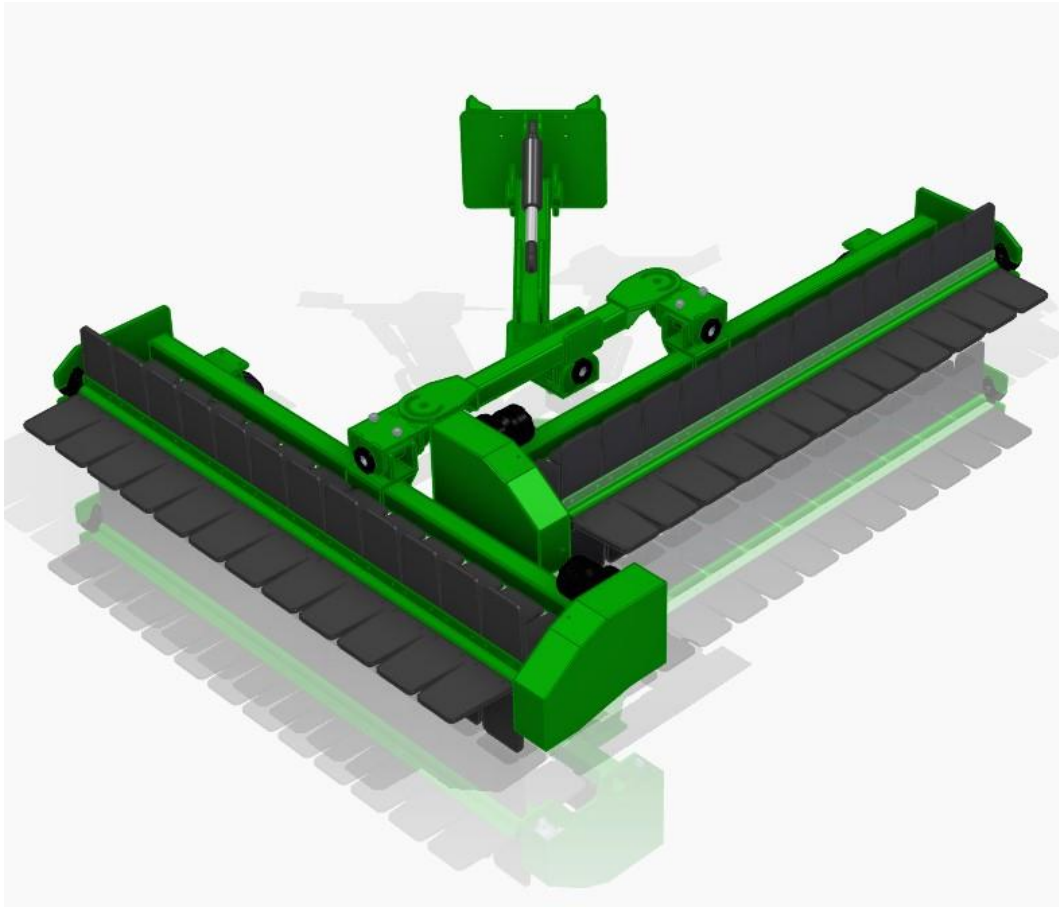

## CART + BIG BAG





## FRAME + BIG BAG

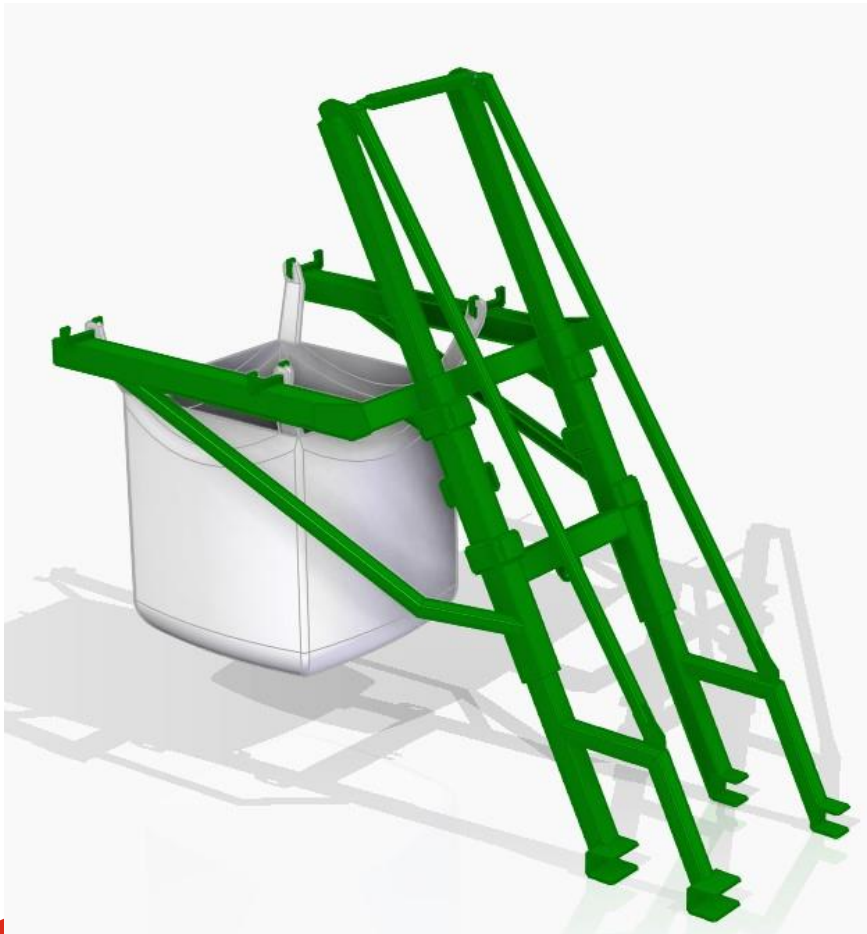

## EASY-PICKER WITH DOUBLE-SIDED HARROW DIMENSIONS

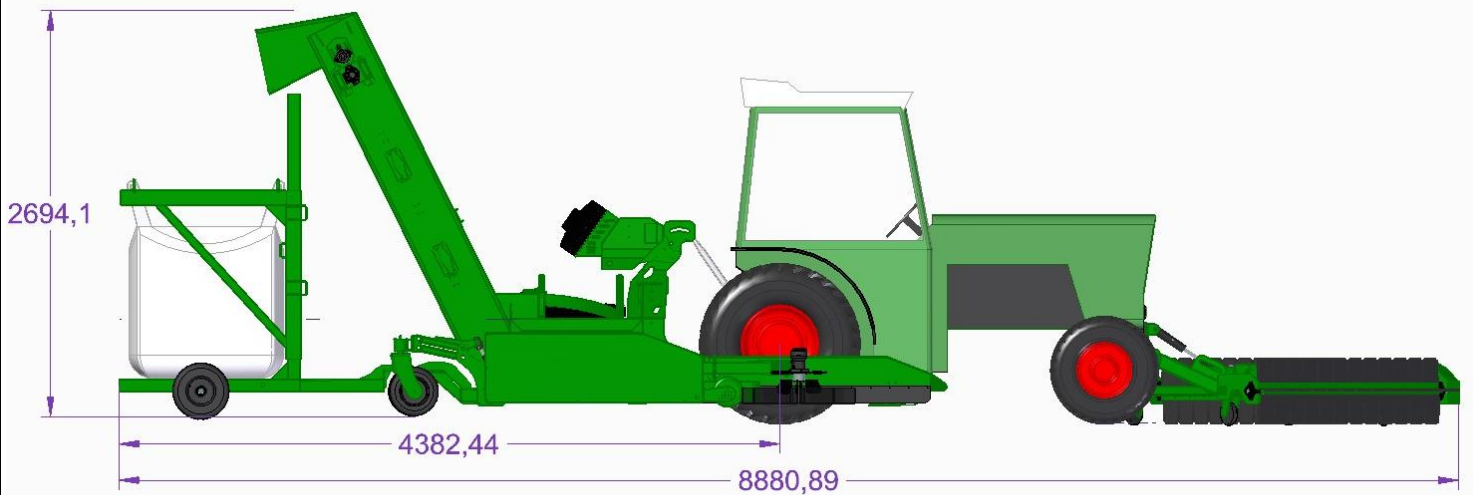
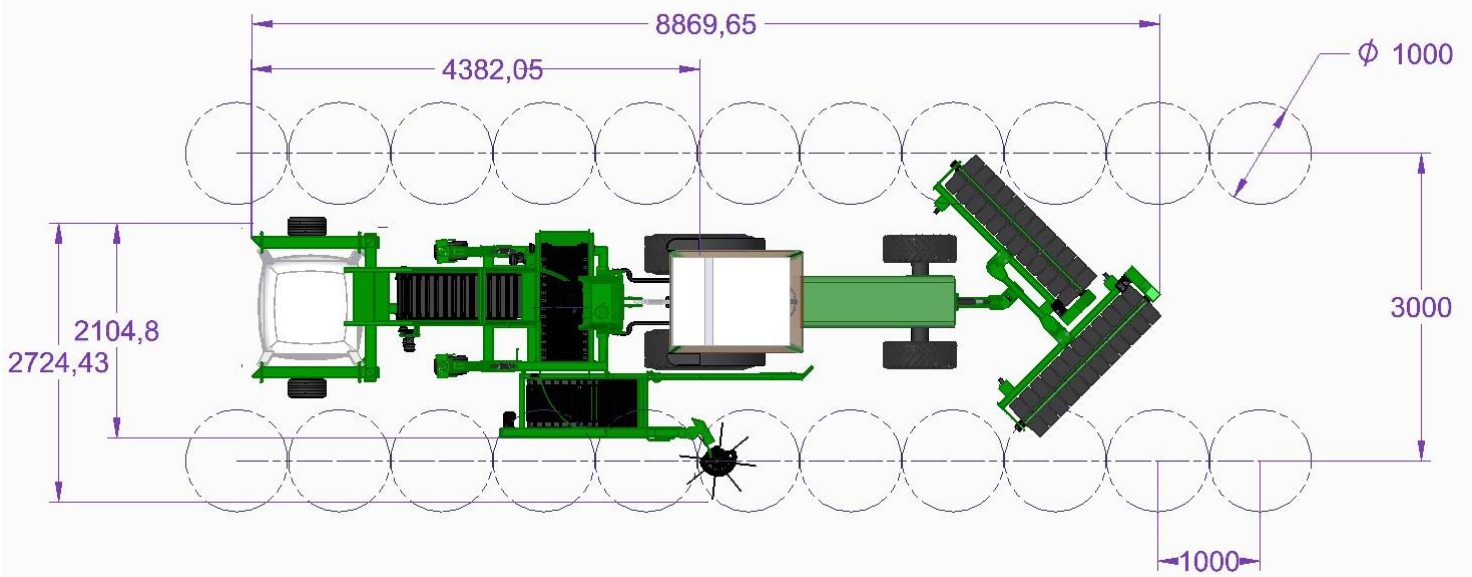
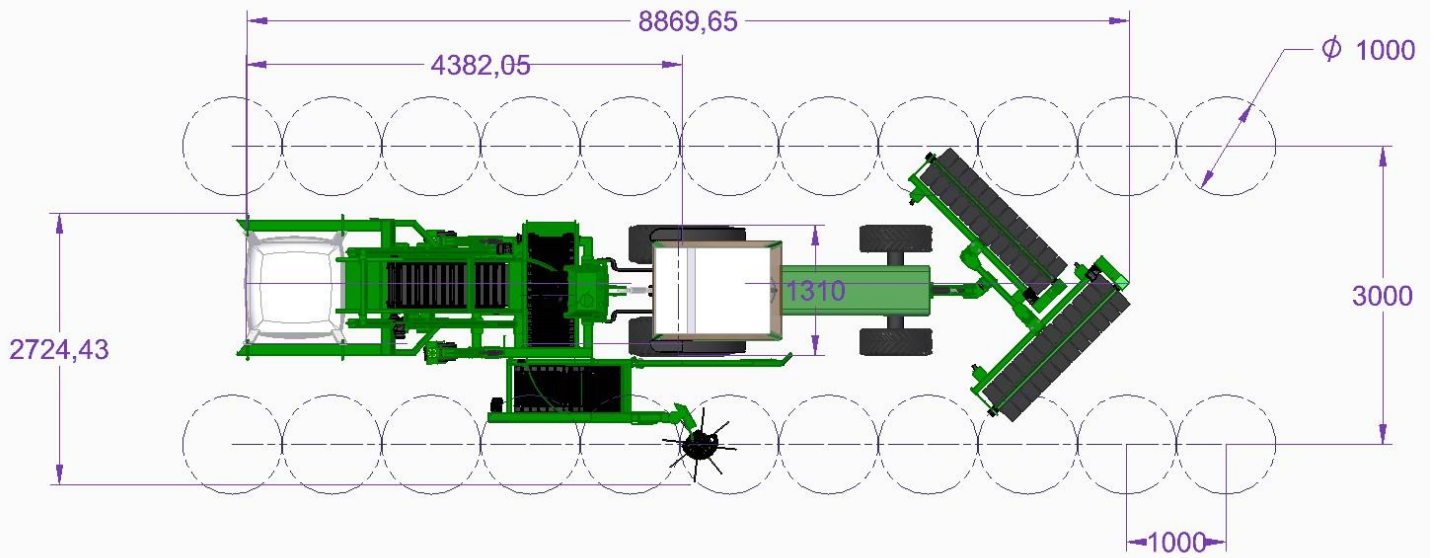

## EASY-PICKER WITH ONE-SIDED HARROW DIMENSIONS

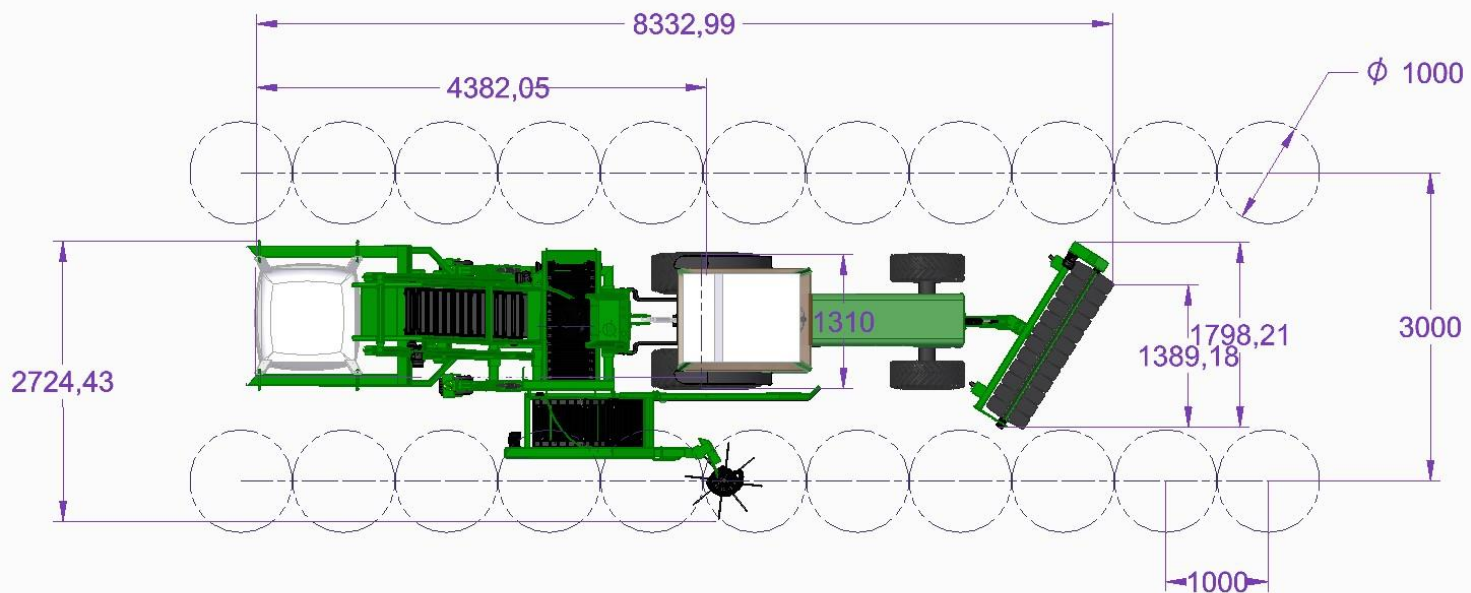

## SLEEVE FOR FILLING BOXES





# READY EASY-PICKER

